

TECHNICAL SPECIFICATIONS ROCKWHEEL G60

The Hydraulic Cutting Unit Rockwheel G60 can be supplied with either scaling/grinding or rock cutting drums.

Hydraulic Power	220 kW
Maximum Oil Flow	680,0 l/min
Optimum Oil Flow	540,0 l/min
Maximum Pressure	400 bar
Cutter Torque	56.068 Nm @ 350 bar
Pick Force	154 kN @ 350 bar
Drum Speed	54 rpm @ 540 l/min
Pick Speed	2,0 m/s @ 540 l/min
Operating Weight	2.478 kg
Excavator Size	50 - 70 t
No. of Picks	56 [38/30 mm Stepped Shank]

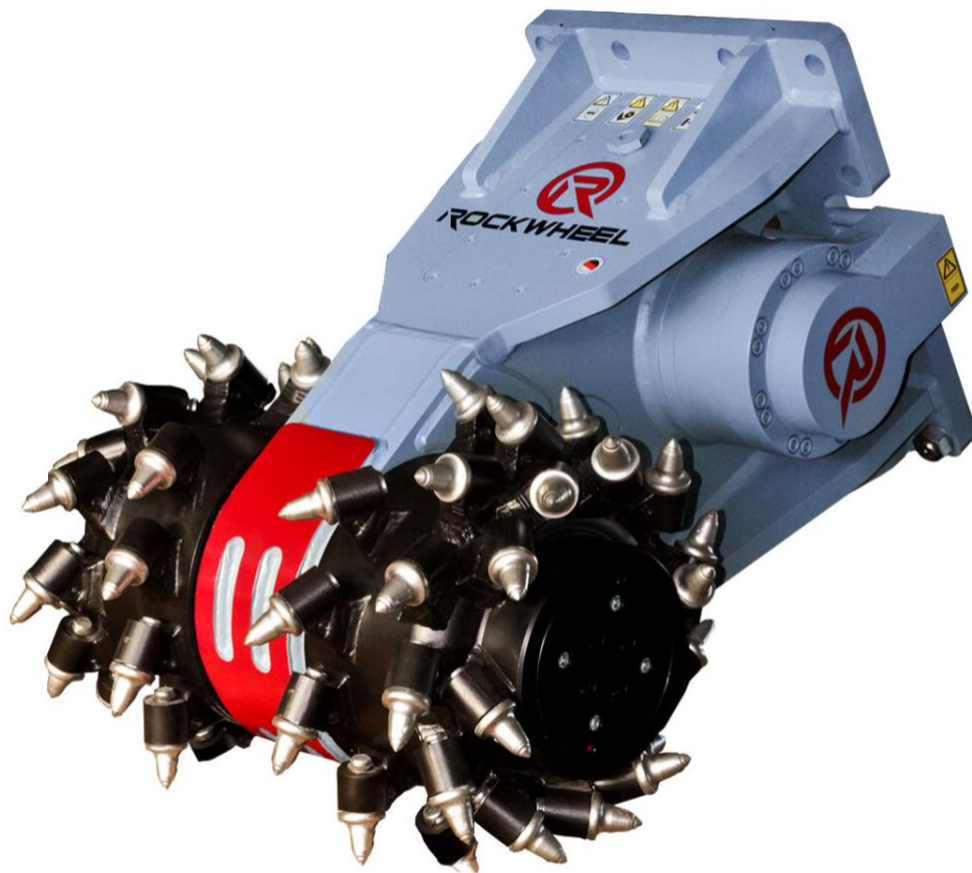

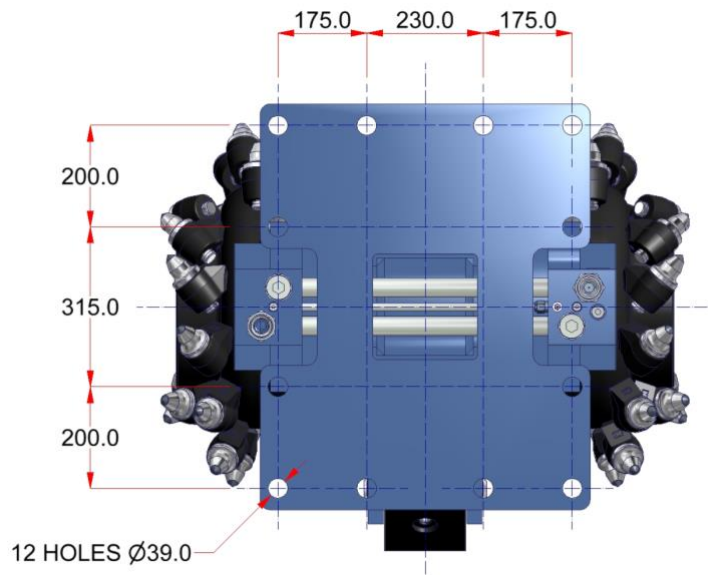
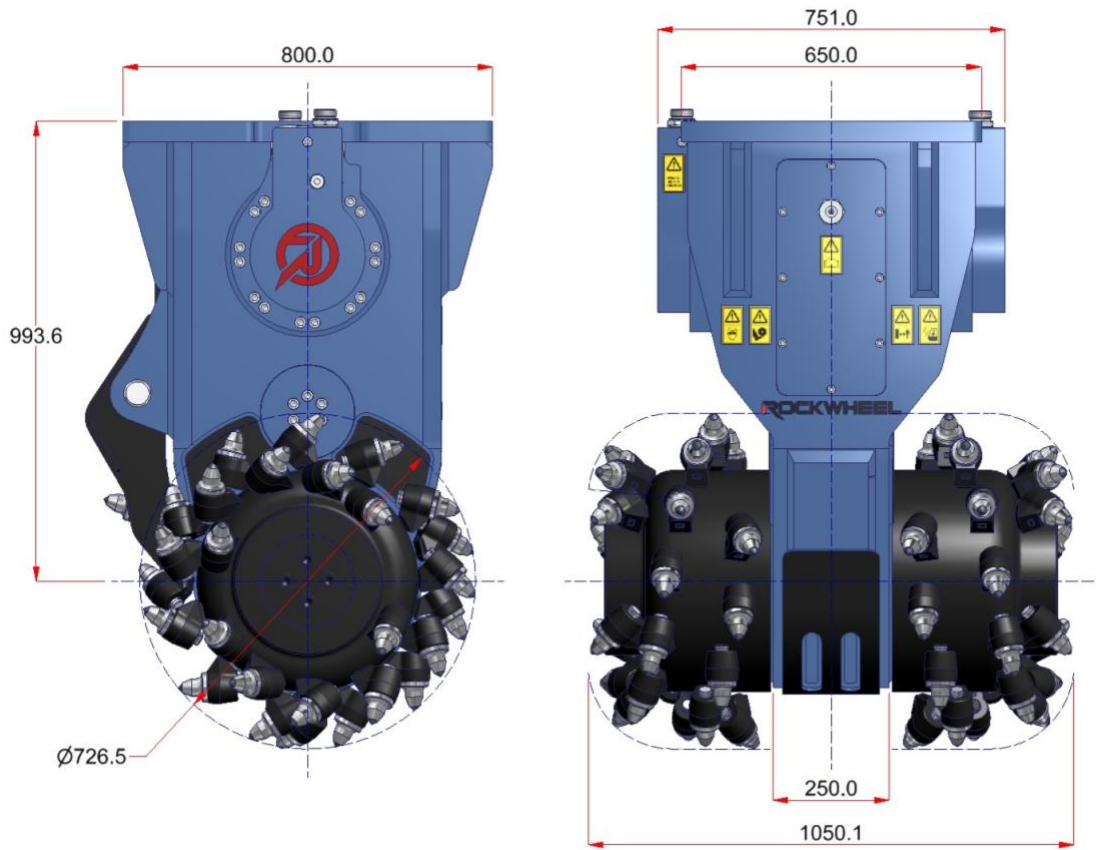

Rockwheel Cutting Units are designed and patented by Webster Technologies Ltd., UK.