

TECHNICAL SPECIFICATIONS ROCKWHEEL D30

The Hydraulic Cutting Unit Rockwheel D30 can be supplied with either scaling/grinding or rock cutting drums.

Hydraulic Power	110 kW
Maximum Oil Flow	460,0 l/min
Optimum Oil Flow	320,0 l/min
Maximum Pressure	400 bar
Cutter Torque	23.362 Nm @ 350 bar
Pick Force	68,9 kN @ 350 bar
Drum Speed	76,2 rpm @ 320 l/min
Pick Speed	2,7 m/s @ 320 l/min
Operating Weight	1.444 kg
Excavator Size	26 - 38 t
No. of Picks	60 [38/30 mm Shank]

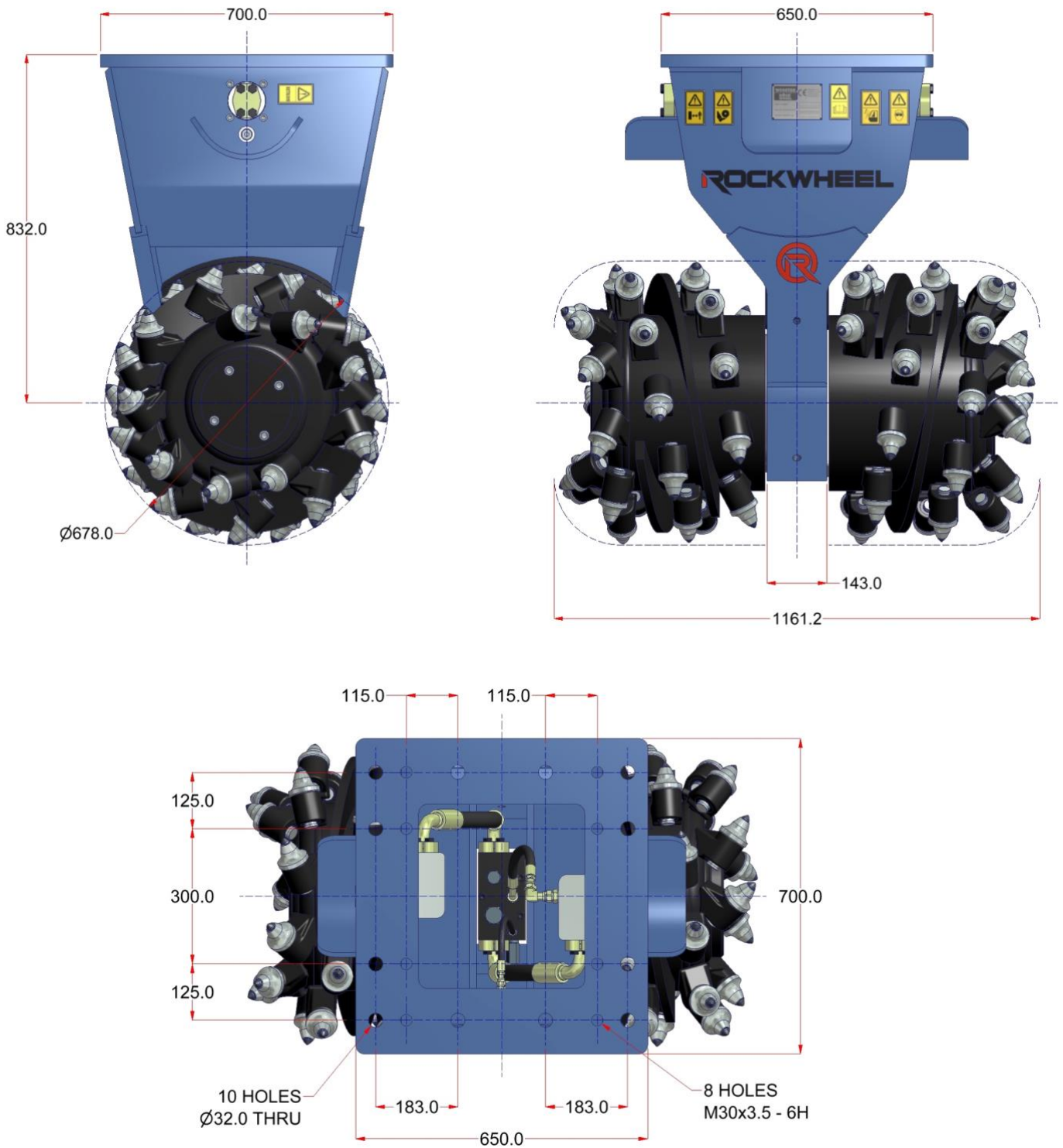



Rockwheel Cutting Units are designed and patented by Webster Technologies Ltd., UK.