

TECHNICAL SPECIFICATIONS ROCKWHEEL CB30

The Hydraulic Cutting Unit Cut & Load Bucket CB30 can be supplied with either scaling/grinding or rock cutting drums.

Hydraulic Power	110 kW
Maximum Oil Flow	460,0 l/min
Optimum Oil Flow	320,0 l/min
Maximum Pressure	400 bar
Cutter Torque	21.376 Nm @ 350 bar
Pick Force	69 kN @ 350 bar
Drum Speed	76,0 rpm @ 220 l/min
Pick Speed	2,7 m/s @ 220 l/min
Operating Weight	1.968 kg
Excavator Range	26 - 38 t
No. of Picks (Rock Drums)	60 (38/30 mm Shank)
Struck Volume	0,62 m ³
SAE Volume	1,09 m ³

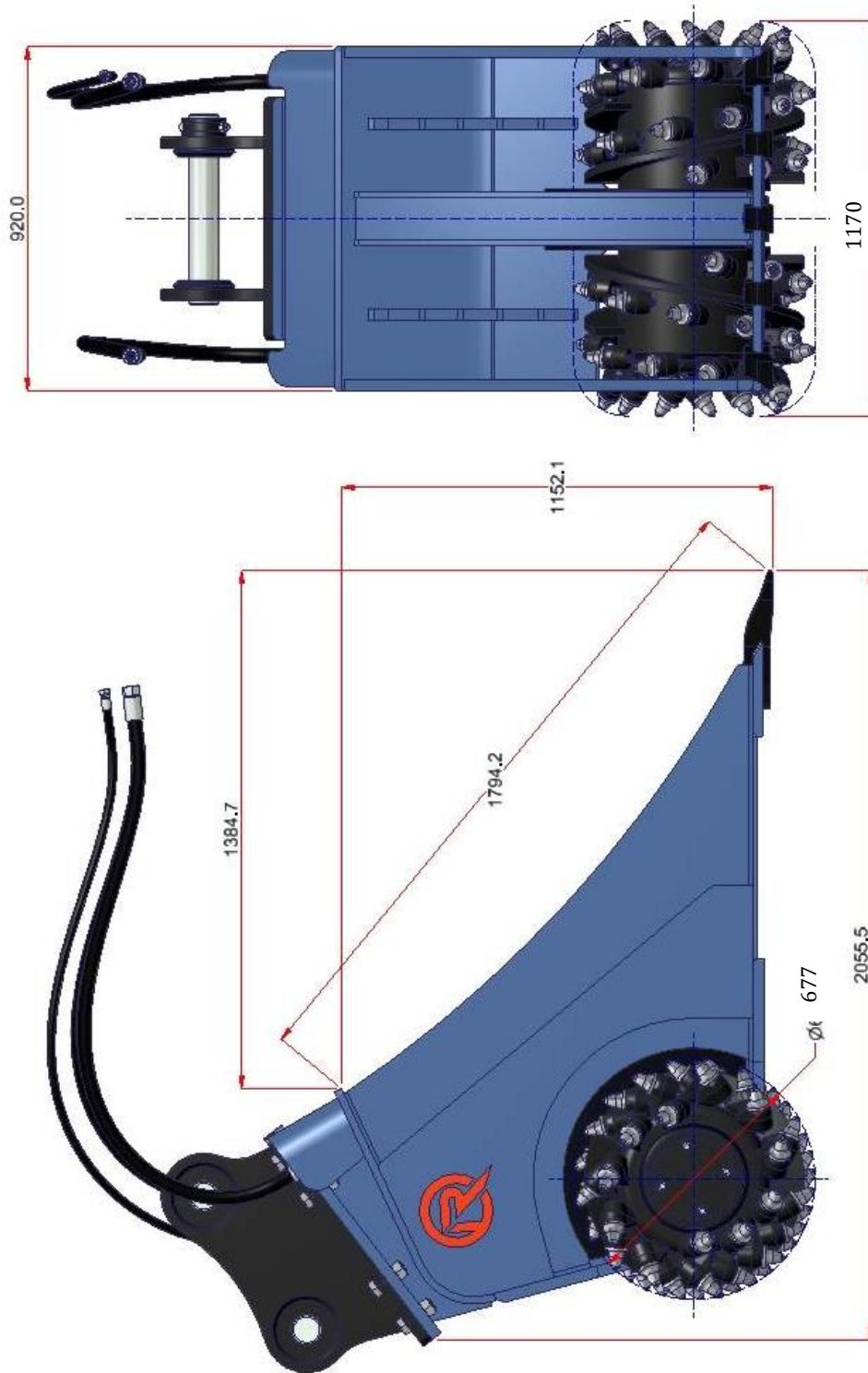



Rockwheel Cutting Units are designed and patented by Webster Technologies Ltd., UK.