

TECHNICAL SPECIFICATIONS ROCKWHEEL CB15

The Hydraulic Cutting Unit Cut & Load Bucket CB15 can be supplied with either scaling/grinding or rock cutting drums.

Hydraulic Power	41 kW
Maximum Oil Flow	132,0 l/min
Optimum Oil Flow	120,0 l/min
Maximum Pressure	400 bar
Cutter Torque	6.945 Nm @ 350 bar
Pick Force	29,2 kN @ 350 bar
Drum Speed	96,2,0 rpm @ 120 l/min
Pick Speed	2,4 m/s @ 120 l/min
Operating Weight	951 kg
Excavator Size	12 - 18 t
No. of Picks (Rock Drums)	64 (19,4 mm Shank)
Struck Volume	0,25 m ³
SAE Volume	0,42 m ³

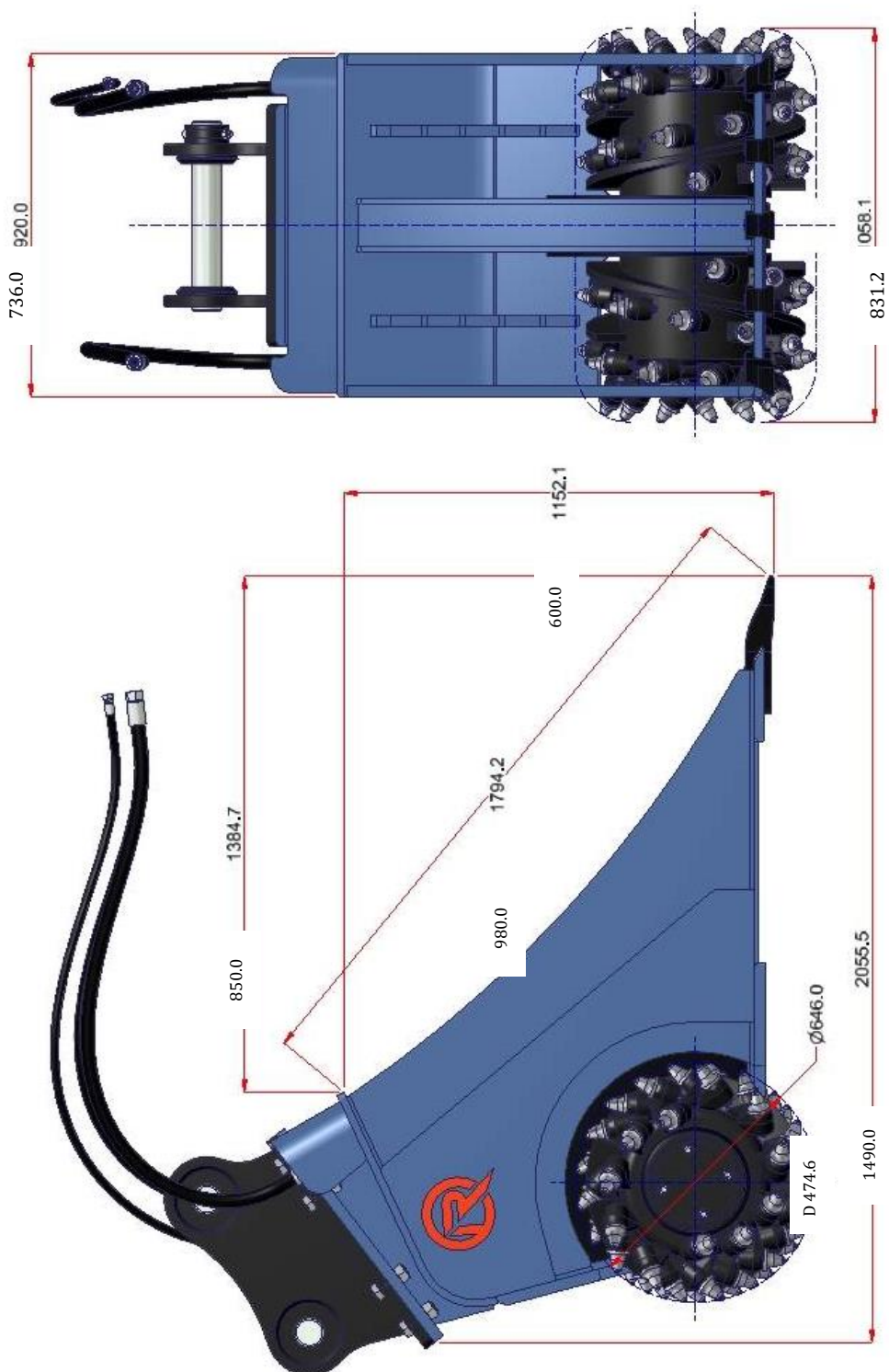



Rockwheel Cutting Units are designed and patented by Webster Technologies Ltd., UK.